

USER MANUAL

MINI F **Wi-Fi**
FULL HD ACTION CAM



 1080P 30 FRAMES PER SECOND	 120° WIDE VIEW ANGLE	 55M WATERPROOF CASE	 BUILT-IN Wi-Fi
 HDMI SUPPORT HEAPS OUTPUT	 REMOTE CONTROL	 32GB MAX. CAPACITY STORAGE	 ACCESSORIES INCLUDED

APP – SEARCH FOR "NILOX MINI F WI-FI"



SUMMARY

PREFACE	4
PRECAUTIONS.....	4
DESCRIPTION.....	5
TECHNICAL SPECIFICATIONS	6
STRUCTURE	7
OPERATING INSTRUCTIONS.....	8
Charge	8
Inserting and removing the memory card	8
USE WITHOUT WI-FI APPLICATION.....	9
LCD DISPLAY AND KEY TO SYMBOLS.....	9
Make a video or take a photo:	9
Output and video viewing devices.....	10
CANCELLATION OF A FILE AND CARD FORMATTING (with monitor connected only)	10
USE WITH WI-FI APPLICATION.....	11
Activation App installation.....	11
Application for android and application for iOS.....	11
Android	11
iOS.....	12
Parameter settings	12
Burst mode.....	12
Car mode.....	12
Slow Motion.....	12
White balance.....	12
Format	13
Playback and delete.....	13
COMPUTER CONNECTION	14
REMOTE CONTROLLER.....	15
PRECAUTIONS.....	16
Precautions for the camera case.....	16
Precautions for the 3M dual-side foam tape.....	16
INCLUDED IN THE PACK	17
WARRANTY AND LEGAL NOTES	18

PREFACE

Thank you for choosing MINI F Wi-Fi, the high-definition digital camera.

Easy to use, compact and with an integrated design.

With its high-definition and dynamic image capturing technology it can record your daily activities at anytime and anywhere,

so you can remember your experiences and share them with your family and friends.

This manual will clearly explain you how to use and install the video camera, providing detailed information as well as technical specifications.

Please read this Manual carefully before the use and keep it for long-term reference.

PRECAUTIONS

Please observe the following points when using MINI F Wi-Fi:

- Do not drop, hit or shake the camera.
- Keep the device away from any electromagnetic source, such as magnets or electro motors, or from any other object emitting strong radio waves, like antennas. Strong magnetic fields may cause failures to the camera or damages to image and audio.
- Do not expose the camera to high temperatures or to sunlight directly.
- Keep the memory card away from electromagnetic sources, such as TVs, speakers or magnets.
- Do not put it in any place with potential static, as the data stored may be lost.
- If the device overheats, smokes or smells in charging, please disconnect the power supply immediately.
- Keep the video camera out of the reach of children when charging, as the power cord may cause accidental suffocation or electric shock.
- Keep the camera in a cool, dry and dust-free place.
- Use a lens and screen guard to prevent scratching or permanent damages.
- Use a cloth and specific products to clean the lens and screen; do not use any organic solvent.

DESCRIPTION

The MINI-F Wi-Fi camera is able to perform the following functions:

- | High definition (HD) video recording and photos.
- | Real-time image display.
- | Recorded Video recall function.
- | Photo files recall function.
- | 2.0 USB High-Speed data transfer.
- | USB cable for battery charging.
- | All accessories are easy to use to facilitate shooting in any place and at any time.

Supplemented by its accessories, this product is the result of multiple patented technologies and can be used for recording anything, anytime, anywhere.

TECHNICAL SPECIFICATIONS

MINI-F WI-FI camera has the following specifications:

- Image sensor: 5.0 mega-pixel CMOS
- Functions: Video recording, photo, preview (on external screen or smartphone/tablet)
- Photo resolution: 8M (3264x2448), 5M (2592x1944)
- Video resolution: FHD (1920x1080 30fps), HD (1280x720 30fps), HD (1280x720 60fps)
- External memory: TF card (Maximum 32GB)
- Audio/video output: Mini HDMI
- File format: JPEG, H.264
- USB Port: USB 2.0
- Battery: Internal 3.7V 1000 mAh rechargeable lithium battery
- G-sensor
- Wi-Fi: up to 20 metres without architectural barriers
- Apps: for iOS and Android
- Remote control: included and remotable via App from smartphone/tablet
- Supported operating systems: Windows XP/Vista/7/8, Mac 10.2
- Dimensions: 61x383x25 mm
- Weight: 68 gr

STRUCTURE

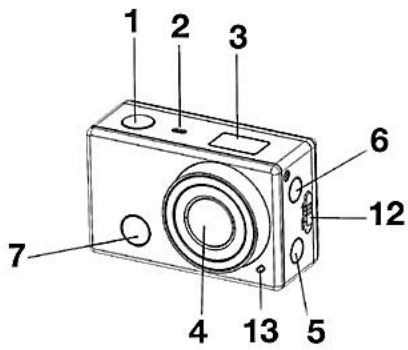

- 1. Shutter button
- 2. Microphone
- 3. LCD Display
- 4. Lens
- 5. Wi-Fi switch and status indicator (red)
- 6. On/off - status change switch
- 7. Infrared reception light signal

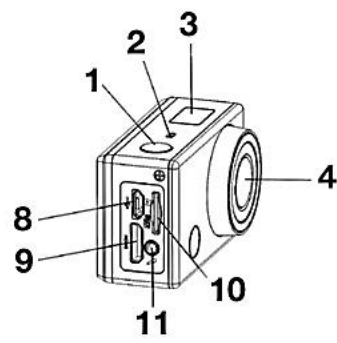

- 8. Micro USB port
- 9. Mini HDMI port
- 10. Micro SD slot
- 11. External microphone
- 12. Battery lock button
- 13. Wi-Fi status led

OPERATING INSTRUCTIONS

MINI-F Wi-Fi can be used in stand-alone mode, using the information at the top of the LCD screen or by downloading the specific APP.

This way, it can be managed via Wi-Fi from a smartphone or tablet.

CHARGE

Turn on the video camera and check battery status; if low, charge it.

Either a computer USB port or power adapter (not included) can be used to charge it.

Generally, it takes 2-4 hours to complete the charge cycle.

INSERTING AND REMOVING THE MEMORY CARD

The MINI-F Wi-Fi video camera supports TF memory cards with capacity up to 32 GB.

Any type of Micro SD card can be used but we recommend high speed cards to optimise performance.

- Installation.

1. Make sure the video camera is off.

2. Insert the card in its slot, being careful that it is inserted in the correct direction until a click is heard.

- Removal.

Turn off the video camera.

2 Press the centre of the back of the card and release it; then remove it.

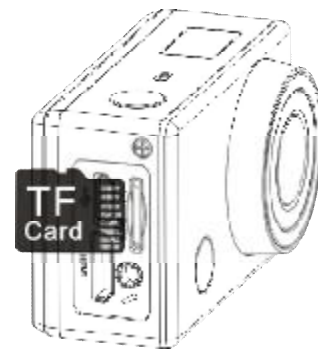

USE WITHOUT WI-FI APPLICATION

LCD DISPLAY AND KEY TO SYMBOLS

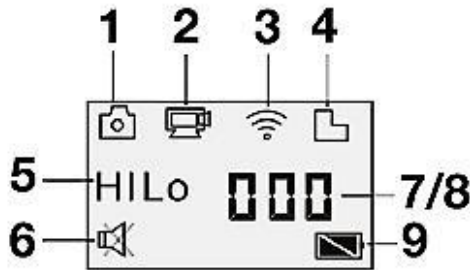

1. Camera mode
2. Video recording mode (default)
3. Wi-Fi enabled
4. Micro SD inserted
5. Resolution (see below)
6. Mute mode (buzzer), displayed if active, disabled by default
7. Counter, goes up to 999 if in photo mode
8. Recording time, if in video mode
9. Battery level

Resolution

Photo camera mode:

HI = 8 Mega Pixel (3264x2448)

LO = 5 Mega Pixel (2592x1944)

Resolution



Video recording mode,

HI = Full HD (1920x1080, 30 fps)

HILO = 720P (1280x720, 60fps)

LO = 720P (1280x720, 30 fps)

MAKE A VIDEO OR TAKE A PHOTO:

Switch the MINI F Wi-Fi on ; when you press  repeatedly, the different camera modes will appear accompanied by a beep.



Video Mode
Full HD (1920x1080, 30)



Video Mode
720P (1280x720, 60fps)



Video Mode
720P (1280x720, 30 fps)



Photo mode
5 Mega Pixel (2592x1944)



Photo mode
8 Mega Pixel (3264x2448)

In video mode, press  to start recording, the counter will show elapsed recording time.

Press  again to stop recording.

In camera mode, press  to take a picture.

OUTPUT AND VIDEO VIEWING DEVICES

The MINI F Wi-Fi has a USB data transfer port and an HDMI output.

Using the USB connector you can:

- Alimentare la videocamera MINI F WI-FI
- Connect the MINI F Wi-Fi video camera to a computer in order to read the data in the memory and micro SD card.

Using the HDMI connector you can:

- Connect the video camera to an external device (TV or computer monitor)

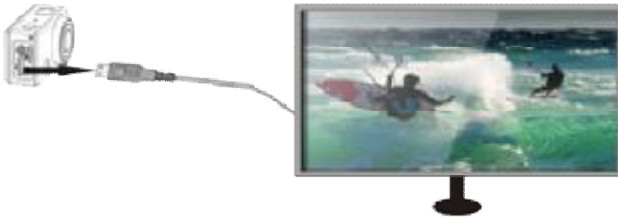

You can connect the MINI F Wi-Fi to a monitor or TV with an HDMI input socket using a suitable cable (not supplied).

This will allow you to view films or photos you have taken.

Before connecting or disconnecting the cam to a monitor, make sure the camera is switched off.

Three symbols will appear on the LCD display:

- 1) Viewing mode
- 2) The file number in order; this screenshot shows number nineteen out of thirty-one
- 3) The file being viewed is a video file



In preview mode, press  to change from photo display to video display mode.

Press  to select the file you want. The  button starts and stops the replay.

When you select a video file, press the shutter button to replay it. Press same button again to stop.

CANCELLATION OF A FILE AND CARD FORMATTING (WITH MONITOR CONNECTED ONLY)

Files can be deleted or cards formatted when the HDMI output is connected to a monitor or TV.

Press and hold down the , button, a menu will appear asking if you want to cancel the file or format the card.

Press  to alternate between cancellation and formatting.

Press  and then  to confirm.

USE WITH WI-FI APPLICATION

You can control your MINI-F from your smartphone or table by downloading the specific APP for iOS or Android.

ACTIVATION APP INSTALLATION

Find" NILOX MINI F Wi-Fi" in Google Play (for Android OS) or APP Store (for iOS) and install it on your smartphone or tablet.

Once installed on your device, the  icon will appear.

- Insert the microSD card, turn on MINI F Wi-Fi and press  to activate device Wi-Fi connections.
- The word Wi-Fi will appear on the screen.
- Search for available Wi-Fi networks on your smartphone/tablet.
- Look for the MINI F Wi-Fi network.
- User name = MINI F Wi-Fi
- Password = Nilox1234
- Make sure the connection is established.
- Launch the application.

Your smartphone or tablet screen can now be used as a remote screen.

APPLICATION FOR ANDROID AND APPLICATION FOR IOS

Android

A preview of what is displayed on the MINI-F Wi-Fi will appear on the screen as soon as the connection is established.



- 1) Recording mode and recording time
- 2) Parameter settings menu
- 3) Playback menu
- 4) Video recording or photo
- 5) Photo/video mode switch
- 6) White balance
- 7) Battery level
- 8) Wi-Fi connection

iOS



- 1) Battery level
- 2) Recording mode and recording time
- 3) White balance
- 4) Parameter settings menu
- 5) Playback menu
- 6) Video recording or photo
- 7) Photo/video mode switch

The symbol that appears on your smartphone or table is very similar whether you are using Android or iOS; some symbols are extremely intuitive. Let's take a look at the most significant ones:

PARAMETER SETTINGS

It lets you edit some specific MINI F Wi-Fi parameters.

Burst mode

This value lets you change the number of photos taken when the shutter button is pressed and, more specifically:

- Off
- 3 photos
- 5 photos
- 10 photos
- Continuous (photos taken until the button is released)

White balance

This lets you achieve higher brightness and colour saturation according to the weather and lighting conditions.

Possible choices are:

- Automatic
- Daylight
- Cloudy
- Fluor
- Tungsten

Format

It lets you format the microSD card.

Possible choices are:

- Yes, No



WARNING, FORMATTING DELETES ALL DATA ON THE CARD.

PLAYBACK AND DELETE

Playback mode lets you view and manage photos and videos.



To view videos, first download them from the camera to the device using the  icon on the bottom right.

Press the icon on the bottom left to alternate images  with the bin .

The bin lets you delete the selected files.

Photos, vice versa, are directly displayed on the screen. Use the arrows on the sides to scroll images.



COMPUTER CONNECTION

Turn on MINI F Wi-Fi and connect it to the PC USB port using the specific cable.
The camera is automatically recognised as a remote disk drive.

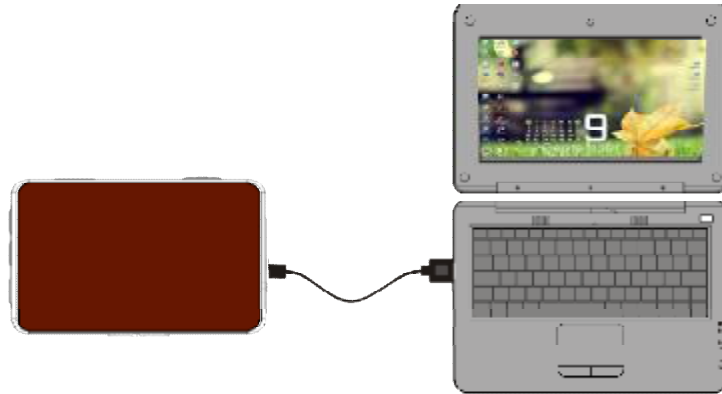

PCU

The word PCU will appear on the screen.

Now you can view your photos or videos on the PC.

Two remote disk drives will appear on the computer:

The first is the memory card containing the photos and videos; the second stores system information including the SSIID_PW.CRG file that contains your Wi-Fi connection username and password.

This information is read only.

REMOTE CONTROLLER

MINI-F comes with a remote controller.

The remote controller, obviously, only runs a limited number of functions.

It can:

- Turn the camera off (red key)
- Take photos (white key)
- Start and stop recording videos



PRECAUTIONS

PRECAUTIONS FOR THE CAMERA CASE

The waterproof case is a precision component. Please use the following precautions:

- Do not randomly dismount and mount the O-ring of the case, keys and lens cover, otherwise the waterproof performance deteriorates.
- Do not put the case in a place where corrosive gases are easily generated due to the existence of strong acid or alkali and keep it away from chemical or corrosive substances.
- Do not store the product in a place where temperature is too high (over 50°C) or low (-10°C) for a long time to avoid deformation.
- Do not expose to direct sunlight for long periods to prevent deterioration of waterproofing.
- Before every use, ensure that the O-ring is intact, that there are no foreign bodies on the seal, that the case is properly sealed and that the seal is watertight.
- After use in salt water, immediately rinse the case under running water.
- Use a dry cloth to dry the surface and store the device in a dry and ventilated place.

PRECAUTIONS FOR THE 3M DUAL-SIDE FOAM TAPE

When using the 3M dual-side foam tape, adhere to the following precautions:

- Before fixing the 3M dual-side foam tape, select a proper surface to ensure proper contact between the foam tape and the surface.
- Before using the 3M dual-side foam tape, clean the surface and heat the foam tape, using for instance an electric blower, especially in a place where temperature is lower than 0°C.

Before using MINI F Wi-Fi video camera, pay attention to the following notice information:

- During continuous use, the body temperature of MINI-F Wi-Fi video camera increases. The situation is normal. The camera surface may be hot after prolonged use.
- If the video camera is not used for a long time, remove and keep the battery properly and recharge it every three months to ensure the battery performance.
- Shooting view angles are slightly different in different working modes of the video camera.
- If a video file is large in size, a computer or other professional players are preferred for a smooth playback.
- Cyclic recording and frequent recording/deleting operations may leave data fragments in the SD card, causing failure to file recording or saving. To solve this problem, just backup the data on an external storage and format the SD card.

INCLUDED IN THE PACK

The articles included in the pack are the following:

1 MINI-F complete with underwater case		1 remote controller	
1 microSD card		1 flat plate and 1 curved plate	
1 hook support			

WARRANTY AND LEGAL NOTES

MINI F Wi-Fi is equipped with a rechargeable lithium polymer battery. To reduce the risk of fire, please avoid tampering, falls, contact with water or fire.

To avoid personal injury, electric shock, fire or damage to various parts of the product, please follow the following instructions: **Do not immerse the product without its waterproof case into water**

Personal Safety.

Do not disassemble, repair, alter or modify any part of the O-ring of the product. Do not touch the product with metallic objects or chemicals.

Any failure to comply with what above can cause risks to the person and other people.

In case of malfunctioning of the product, please contact the technical service or a qualified supplier.

Technical support.

This product is warranted in accordance with current legislation and therefore please contact your dealer in case of need of technical assistance and / or warranty service.

Instructions for the environment



This product may contain substances that can be harmful to the environment and to the human health, if not disposed of properly. We therefore provide you the following information in order to prevent the release of such substances and to improve the use of natural resources. The electrical and electronic products should not be disposed of in the normal household waste, but should be properly collected in order to be correctly treated. The symbol of the crossed bin shown on the product and in this page reminds the need to properly dispose of the product at the end of its life. In this way you can avoid that a non-specific treatment of the substances contained in these products, or an improper use of parts of them can lead to harmful consequences for the environment and human health. Moreover, you can contribute to the recovery, recycling and reuse of many of the materials composing these products. That is why the manufacturers and distributors of electrical and electronic systems organize the proper collection and disposal of the equipment themselves. At the end of the product life please contact your dealer for instructions regarding the collection. When purchasing this product your distributor will inform you of the possibility to replace your old device with a new one, on condition that the type of product and its functions are the same or, if the dimensions do not exceed 25 cm, AEE can be returned without any equivalent product purchase obligation. Any disposal of the product different from what described above will be liable to the penalties foreseen by the laws in force in the country where the product is disposed of. Moreover we suggest to adopt additional measures

favourable to the environment: recycling the inner and outer packaging and properly dispose of used batteries (if any).

With your help we can reduce the amount of natural resources used for the realization of electrical and electronic equipment, minimizing the use of landfills for the disposal of products and improving the quality of life by preventing to release into the environment potentially dangerous substances.

Installing and replacing batteries



The product contains a battery that could be replaced during the lifetime of the product itself.

At the end of life of the batteries contained in the product, they must be disposed of separately. Throw them in the appropriate containers for the disposal of batteries.

The collection and recycling of batteries contribute to the protection of the environment and to the preservation of material resources, allowing the recovery of valuable materials too.

Declaration of Conformity

Product complies with 1999/5/CE-2011/65/CE Directive. The declaration in full version and the technical documentations are available at our headquarters - Hellatron S.p.A Via E. Mattei 10 20010 Pogliano M.se (MI).

Keep the packaging for future references.

Warranty information

- One year, if invoiced to a company or professional (with VAT number).
- Two years, if fiscally described as sold to a private citizen.
- This warranty is referred to in the event a conformity defect occurs, referred to product features.
- Product support and warranty. Visit www.nilox.com to learn more.

Warranty restrictions: this warranty does not apply in the following cases:

- no proof of purchase (invoice or receipt).
- tampering, forcing and damages on the hardware and screen, created for any reason.
- other defects to to: inappropriate use, unauthorised hardware/software changes, operations or storage beyond technical product specifications; incorrect maintenance; defects due to the use of software other than that supplied and all those elements (hardware and software) not designed to be used with the product.

The above refers to legislative decree dated February 2, 2002. Implementing the 1999/44/CE Directive.



Brief Declaration of Conformity



This device was tested and meets European Parliament and European Commission Directive 2011/65/EC and 1999/5/EC concerning radio equipment and peripheral devices for telecommunications and their mutual recognition. The declaration of conformity is available at our offices.

This device can thus be used in all EEC countries and in all countries where Directive 1999/5/EC applies, without restrictions, except for:

Norway (NO): device not to be used within 20 km of Ny Alesund.

Italy (IT): This peripheral complies with the National Radio Interface and meets requirements on Frequency Assignment. The use of this device beyond the areas where the owner works requires general authorisation. For further information please visit: www.comunicazioni.it.



CE () logo and/or WEEE () logo, in some devices, isn't fully compliant with minimum dimensions requirement to European Directive due to limited sticker area