

Holdit

Professional Variable Arm System



NOGA
SIMPLY SOPHISTICATED

Introduction

If your business is in the image capturing trade whether for the movie industry or the still life commercial field, getting it right involves reliable trusted equipment.

HOLDIT meets these demands.

A flexible double articulated arm that can be positioned to any angle, then locked, can help you in those moments when a bracket fails and a strip of sticky tape just won't do. The 3 jointed arm was designed by Noga Engineering for a variety of high precision industrial applications. Noga then modified the arm to suit a wide range of cameras and it has now become an essential accessory for the professional photographer. The heart of the device is its single central locking knob that simultaneously locks all 3 joints.

So the next time you find yourself in one of those unmanageable moments, HOLDIT will help you do the job.

Those who have used it once never work without it again.



Contents:

Introduction		1
Monitor Cinematography	for the film and TV industry	3
Lighting Heads	for video photography	5
Range of Accessories	options & specifications	7
Stills Studio	for studio photography	8
Complete Sets	set specifications	9

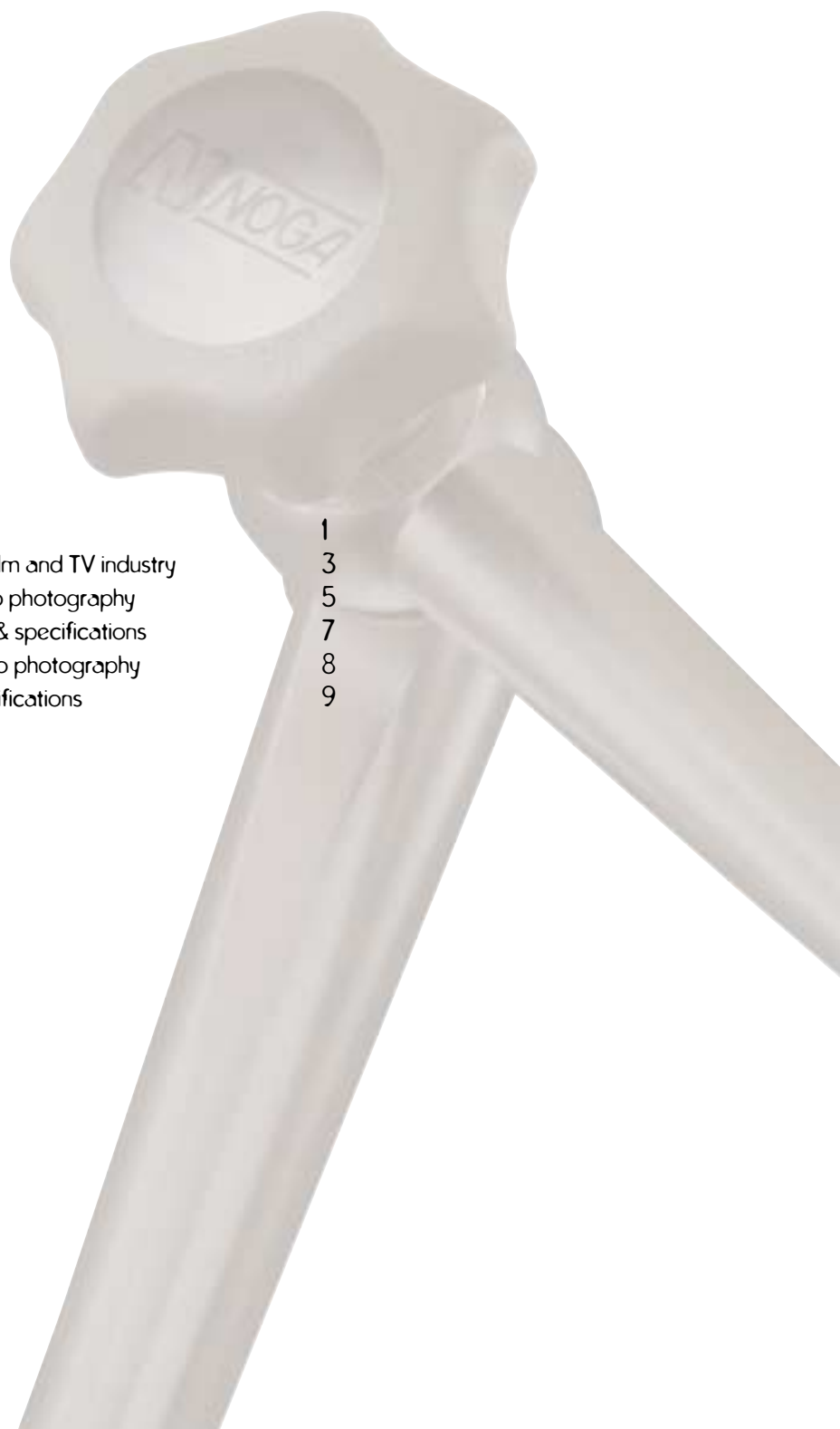

Monitor Cinematography

A flexible arm that can hold a monitor mounted onto your cine camera. Raise or lower, tilt up or down, swing the screen to get the angle you require. The monitor can be turned to any angle to provide you with the clearest view.

To order complete sets see page 10



Holdit



MG11043

Lighting Heads

This versatile flexible arm is a “must” for any serious video cameraman. It mounts easily onto the camera and is quick and simple to use.



DG1105

Holdit

Support your light, move it left or right of the lens. Raise or lower, tilt up or down. Master your shadow, be in control like never before. Prevent burning your microphone windscreen. Soften your light, get rid of the hard shadow, bounce the light off a reflector held by the HOLDIT clamp.

To order complete sets see page 10



Use the clamp to shade your lens.

Range of Accessories

Our extensive range of accessories makes HOLDIT a versatile tool. With the many CLAMPS, MAGNETS & ARMS options, you can customise HOLDIT for your SPECIFIC NEEDS.

M6

M6L65	W/4L7	W/4L14.3	W3/8 L10 Hex 5 Int.	M8 L8 Hex 4 Int.	W/4 L28 Hex 3 Int.	W/4 L28 + Nut	W/4 L44	M6 Ext. M6 Int. L6	M6 L10	ø8 L40	M6 W/4
AD 6060	AD 6010	AD 6011	AD 6030	AD 6081	AD 6012	AD 6013	AD 6014	AD 6061	AD 6000	AD 8000	MA 0125

M6

Top M6

Γ M6 Ext.	Z M6 Ext.
NF 0125	DG 0125

Clamps

NF

0.35kg
076

27kg
66

Bottom M6

Top M6

BOTTOM ARM 56mm
22"

TOP ARM 51mm
2"

TOTAL LENGTH 107mm
42"



NF

Bottom M6

DG

0.324kg
067b

4kg
96

Bottom M6

Top M6

BOTTOM ARM 110mm
4.33"

TOP ARM 101mm
3.97"

TOTAL LENGTH 211mm
8.3"



DG

Bottom M6

MG

0.829kg
184b

8kg
176

Bottom M8

Top M6

BOTTOM ARM 133.5mm
5.25"

TOP ARM 113mm
4.45"

TOTAL LENGTH 246.5mm
9.7"



MG

Bottom M8

MA

29kg
638E

20kg
44E

Bottom M10 x 1.25

Top M6

BOTTOM ARM 326mm
12.83"

TOP ARM 242mm
9.52"

TOTAL LENGTH 568mm
22.35"

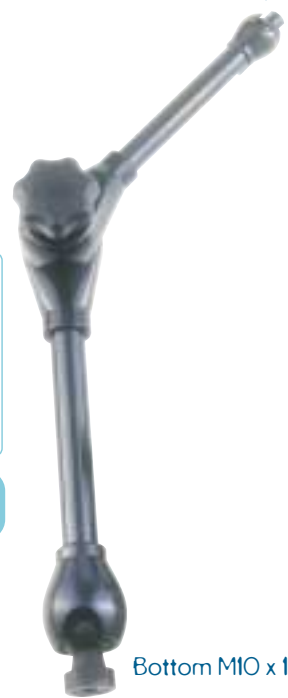

MA

Bottom M10 x 1.25

M6 L6.5	W/4 L7	W/4 L14.3	W3/8 L10 Hex 5 Int.	M8 L8 Hex 4 Int.	W/4 L28 Hex 3 Int.	W/4 L44	M6 Ext. M6 Int. L6	M6 L10	ø8 L40
AD 6060	AD 6010	AD 6011	AD 6030	AD 6081	AD 6012	AD 6014	AD 6061	AD 6000	AD 8000

Vacuum

M8 Int.
DG 0040

M6

3" M8	3" Plast Jaws M8	W3/8 L8.5	M16 x 1 L5	M8 L25 Hex 5 Int.	M8 Ext. Hex 5 Int.	M8 L9	800N M8	1000N M8
MG 1003	MG 0125	AD 8030	AD 8066	AD 8080	AD 8010	AD 6080	DG 0036	DG 0038

M8

1300N M10 x 1.25	4" M10 x 1.25	M10 Ext. Hex 5 Int.	W3/8 L10 Hex 5 Int.	M8 L8 Hex 4 Int.	M10 x 1.25 Ext. M8 Int. L9
DG 0039	MA 0320	AD 1000	AD 1030	AD 1080	AD 1081

M10

Holdit

Stills Studio

Still-life photographers waste valuable time trying to position simple objects. Though their ingenuity can be marvelled at, HOLDIT replaces any tricks with wires, sticky tapes or clamps and clips. Fast and simple, lock your objects with this professional and variable arm.



NEW

Complete Sets

The configuration of the HOLDIT Complete Set range offers the professional photographer optimum flexibility and maximum control while shooting.











NF SETS

DG SETS

MG SETS

Holdit

CAT. NO.	ARMS	TOP EXTERNAL	BOTTOM EXTERNAL	MATERIAL
NF 1104	Black finish NF arm	1/4"-20 plus nut	3/8"-16	Steel
NF 1105	Black finish NF arm	1/4"-20 plus nut	1/4"-20	Steel
DG 11043	Black finish DG arm	1/4"-20 plus nut	3/8"-16	Aluminum
DG 6140	Black finish DG arm	1/4"-20 plus nut	3/8"-16, 5/8 nut adaptor	Aluminum
DG 1105	Black finish DG arm	1/4"-20 plus nut	1/4"-20	Aluminum
MG 11043	Black finish MG arm	1/4"-20 plus nut	3/8"-16	Steel
MG 1106	Black finish MG arm	1/4"-20 plus nut	3/8"-16	Aluminum

	NF-STEEL	DG-ALUMINUM	MG-STEEL	MG-ALUMINUM
	  0.35 Kg 27 Kg 0.7 lb 6 lb	  0.304 Kg 4 Kg 0.67 lb 9 lb	  0.835 Kg 8 Kg 1.84 lb 17.5 lb	  0.517 Kg 6.8 Kg 1.14 lb 15 lb
BOTTOM ARM	56 mm 2.2"	110 mm 4.33"	133.5 mm 5.25"	133.5 mm 5.25"
TOP ARM	51 mm 2"	101 mm 3.97"	113 mm 4.45"	113 mm 4.45"
TOTAL LENGTH	107 mm 4.2"	211 mm 8.3"	246.5 mm 9.7"	246.5 mm 9.7"



Production: studio-tefenwww.studio-tefen.co.il

CA58E1106



<http://www.holditarm.com>
e-mail: info@holditarm.com